2835R Series

Standard 2835 package to address retrofit applications

2835R Series is a complementary portfolio with optimized performance and bin construction for the retrofit space. With an industry standard footprint, it provides the perfect balance between performance and cost efficiency for a variety of applications.



FEATURES AND BENEFITS

Flexible voltage configurations to comply with various different system solutions
Industry standard footprint for drop-in replacement designs
High maximum drive current to allow for reduction of LED count

Part Number Nomenclature

Part numbers for the 2835R Series follow the convention below:

L 1 2 8 – A A B B R C 3 5 0 0 D D D

Where:

- AA** - designates nominal CCT (27=2700K, 30=3000K, 35=3500K, 40=4000K, 50=5000K, 57=5700K, 65=6500K)
- BB** - designates nominal CRI (70=70CRI, 75=75CRI, 80=80CRI and 90=90CRI)
- C** - designates voltage (A=3V, B=6V, C=9V, D=18V, E=36V,F=54V)
- DDD** - designates Lumileds internal code (0A1, 0B1, 0C1, etc.=shares the same base part)

Therefore, the following part number is used for a 2835R 3000K, 80CRI, 36V LED:

L 1 2 8 – 3 0 8 0 R E 3 5 0 0 0 A 1

Lumen Maintenance

Please contact your local Sales Representative or Lumileds Technical Solutions Manager for more information about the long- term performance of this product.

Environmental Compliance

Lumileds LLC is committed to providing environmentally friendly products to the solid-state lighting market. The 2835R Series is compliant to the European Union directives on the restriction of hazardous substances in electronic equipment, namely the RoHS Directive 2011/65/EU and REACH Regulation (EC) 1907/2006. Lumileds LLC will not intentionally add the following restricted materials to its products: lead, mercury, cadmium, hexavalent chromium, polybrominated biphenyls (PBB) or polybrominated diphenyl ethers (PBDE).

Mass Production List of 2835R

PRODUCT	PRODUCT NUMBER	CCT	RA MIN	Φ (lm) MIN	Φ (lm) TYP	Φ (lm) MAX	TEST CONDITIONS
2835R 3V	L128-2280RA35002Q1	2200	80	21	22	23	25°C IF=60mA
	L128-2780RA35002Q1	2700	80	26	27	28	
	L128-3080RA35002Q1	3000	80	27	28	29	
	L128-3580RA35002Q1	3500	80	28	29	30	
	L128-4080RA35002Q1	4000	80	29	30	31	
	L128-5080RA35002Q1	5000	80	29	30	31	
	L128-5780RA35002Q1	5700	80	29	30	31	
	L128-6580RA35002Q1	6500	80	29	30	31	

Notes:

- 1.Tolerance of Color Rendering Index ± 2 .
- 2.Tolerance of Luminous flux: $\pm 5\%$.

Absolute maximum ratings (Ta=25°C)

PARAMETER	SYMBOL	VALUE	UNIT
Power dissipation	Pd	495	mW
Forward current	IF	150	mA
Reverse voltage	VR	5	V
Operating temperature range	Top	-35~+100	°C
Storage temperature range	Tstg	-35~+85	°C
Heatresistance	Rth	35	°C
Junction temperature	Tj	125	°C
Electrostatic Discharge	ESD	2000	V

Electro-optical characteristics (Ta=25°C)

PARAMETER	SYMBOL	MIN	TYP	MAX	UNIT	TEST CONDITION
Forward voltage	Vf	2.8		3.3	V	IF=60mA
Luminous flux	Φ	21			lm	IF=60mA
Viewing Angle	2 θ 1/2		120		Deg	IF=60mA
Reverse current	IR			10	uA	Vr=5V
Color Index	Ra	80				IF=60mA

Notes:

- 1.The measurement of forward voltage maintains a tolerance of $\pm 0.05V$, flux maintains a tolerance of $\pm 5\%$.
- 2.Ra measurement tolerance is ± 2 .
- 3.Ra ± 2 .
- 4.Rth j-sp is the thermal resistance from LED junction to solder point on MCPCB with electrical power.
- 5.Rth j-sp

Reliability Test Items And Conditions

TEST ITEMS	TEST CONDITION	TIME	QUANTITY	AC / RE
Reflow Soldering	Temp. :260°C/10sec.	6 Min.	22pcs	0/22
Thermal Shock	-40~125C - 15min dwell - 10sec transfer	100Cycles	22pcs	0/22
High Temperature High Humidity life Test	85°C,85%RH - IF=60mA	1000Hrs.	10pcs	0/10
Low Temperature Storage	Ta=-40°C	1000Hrs.	10pcs	0/10
High Temperature Storage	Ta=100°C	1000Hrs.	10pcs	0/10
High Temperature Operation Life Test	Ta=85°C - IF=60mA	1000Hrs.	10pcs	0/10

Failure Criteria

ITEM	SYMBOL	FAILURE CRITERIA
Luminous Flux	Lm	≥70%
Forward voltage	VF	±10%
Colour	CIE_X - CIE_Y	±0.01

Typical optical characteristics curves

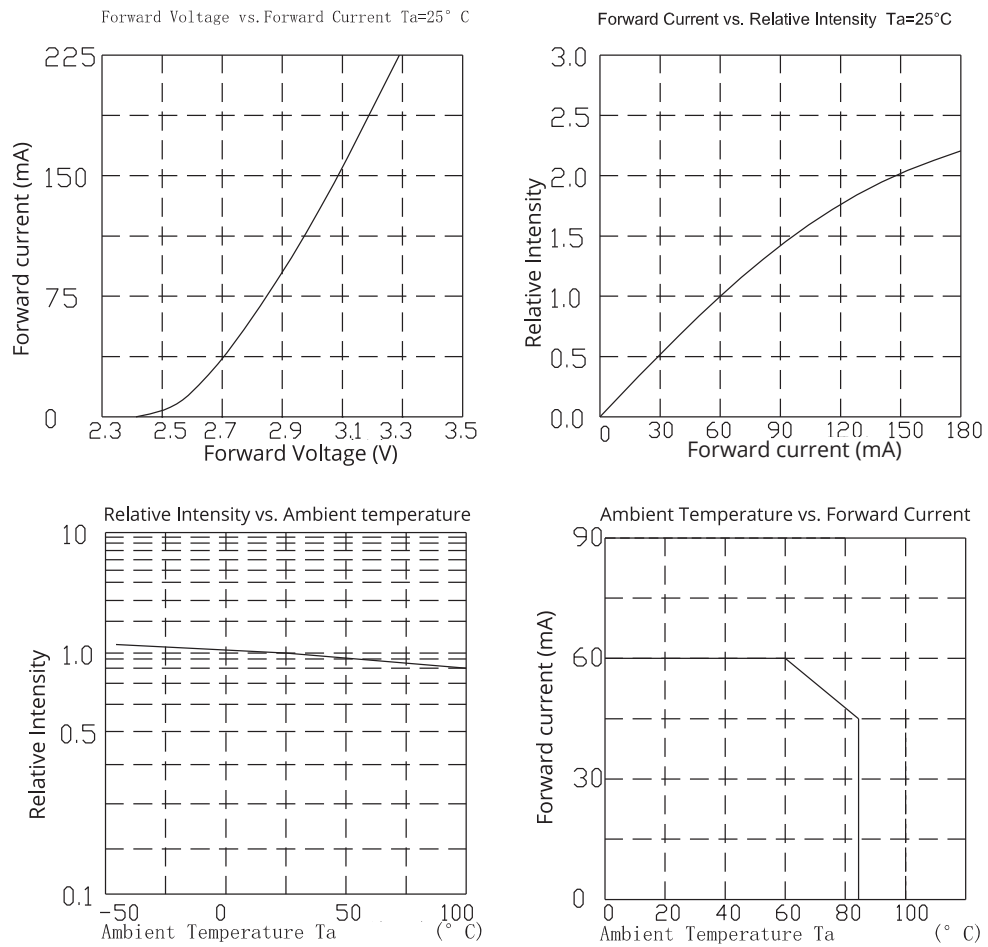

Curves of beam angle and relative brightness

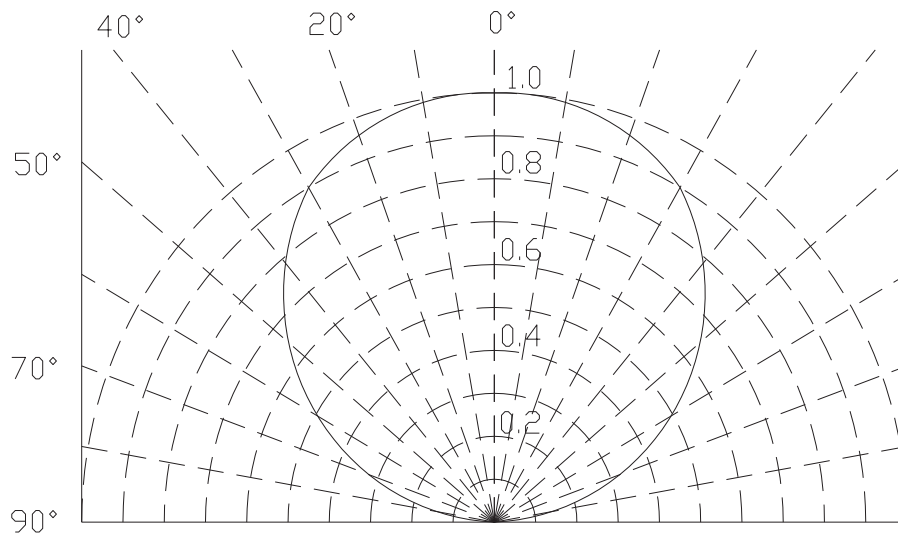

Life Test

Affect of T_j on Luminous Maintenance

($I_f=150\text{mA}$)

(Dot line: Expected Life)

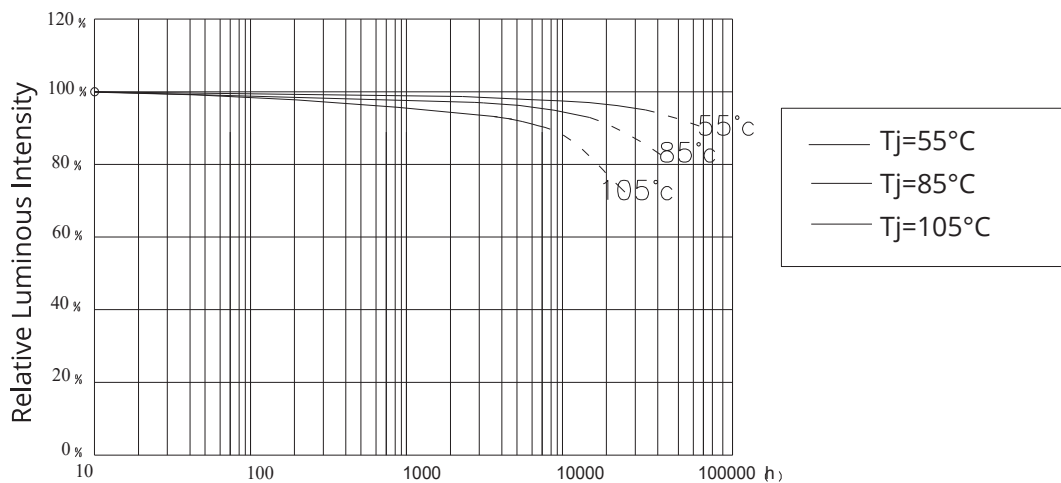

Mechanical Dimensions : Unit (mm)

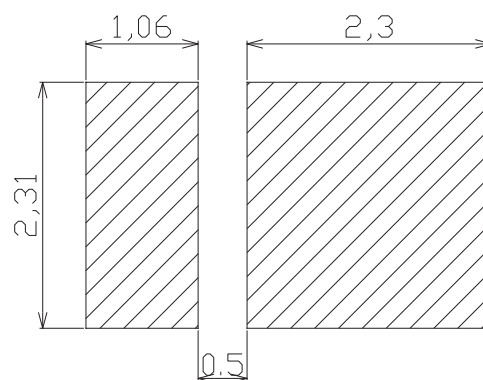
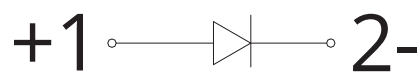
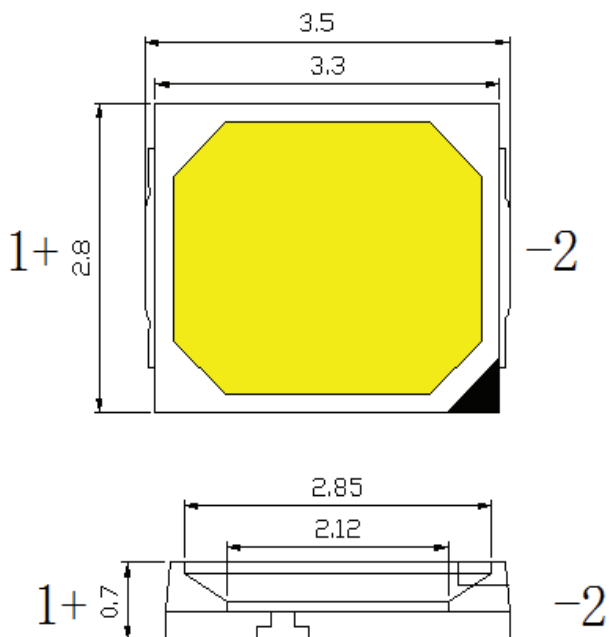

For reflow soldering

Product Bin and Labeling Definitions

Decoding Product Bin Labeling

In the manufacturing of semiconductor products, there are variations in performance around the average values given in the technical datasheet. For this reason, Lumileds bins LED components for luminous flux or radiometric power, color point, peak or dominant wavelength and forward voltage.

2835R Series LEDs are labeled using a 5-digit alphanumeric CAT code following the format below

Where:

A B C D E

A - designates luminous flux bin (example: B=95 to 100 lumens, G=140 to 150 lumens)

BCD - designates correlated color bin (example: A27, A30, A35, A40, A50, A57, A65)

E - designates forward voltage bin (example: B=34.5 to 35.0V, J=38.0 to 38.5V)

Therefore, a 2835R LED with a lumen range of 95 to 100, color bin of A35 and a forwardvoltage range of 38.0 to 38.5V has the following CAT code:

B A 3 5 J

Luminous Flux Bins

Luminous flux bin definitions for 2835R Series at rated current, Ta=25°C .

PRODUCT NUMBER	BIN	MIN	MAX
L128-XX80RA35002Q1	C	21	23
	D	23	25
	E	25	27
	F	27	29
	G	29	31
	H	31	33

Notes:

Lumileds Maintains a tolerance of $\pm 5\%$ on lumionous flux measurements

Forward Voltage Bins

Forward voltage bin definitions for 2835R Series at rated current, Ta=25°C .

PRODUCT NUMBER	BIN	MIN	MAX
L128-XX80RA35002Q1	C	2.8	2.9
	D	2.9	3.0
	E	3.0	3.1
	F	3.1	3.2
	G	3.2	3.3

Color Bin Definition

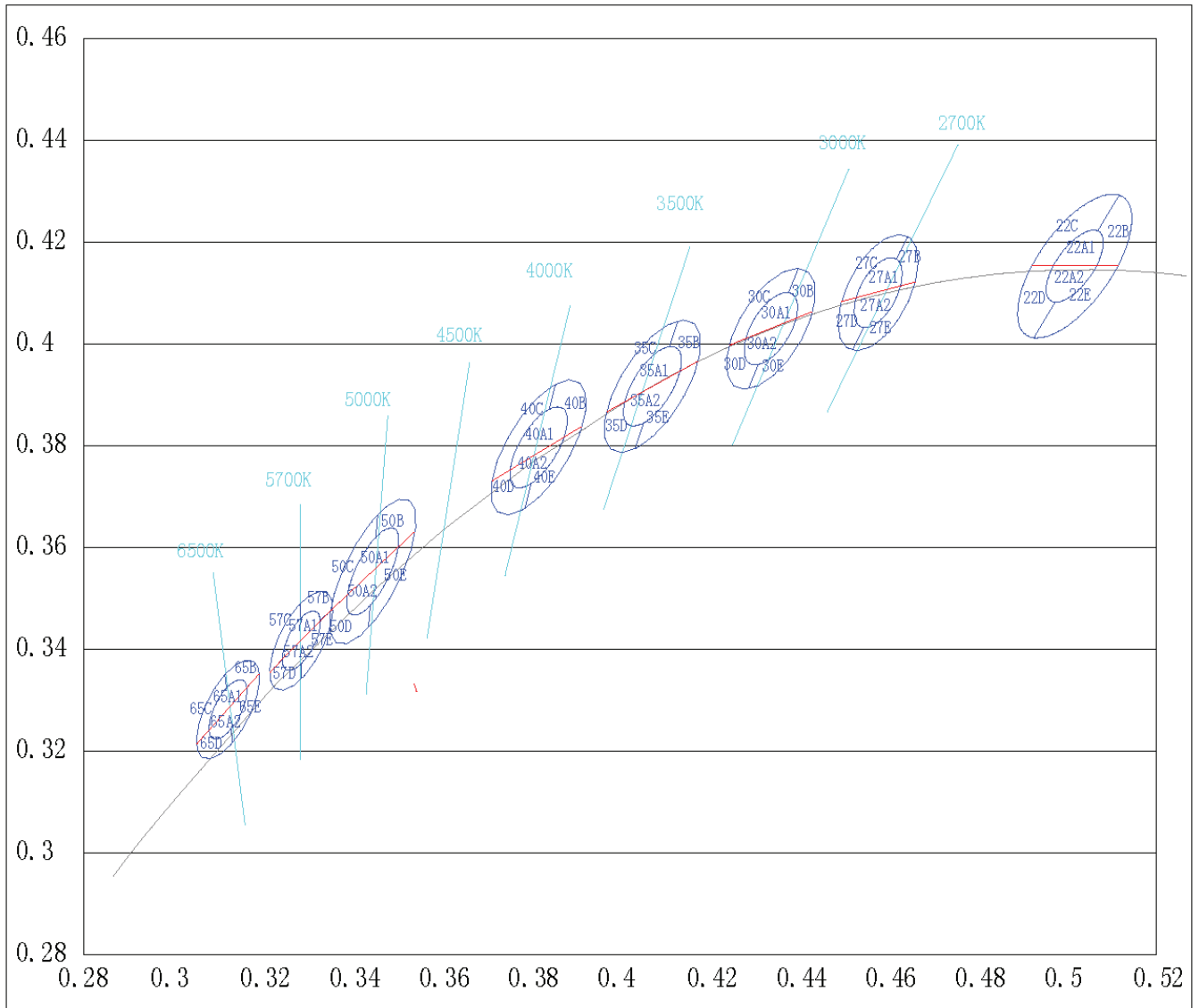

Correlated color temperature bin definitions for 2835R Series at rated current, $T_a=25^\circ\text{C}$

CCT	COLOR SPACE	CENTER X	CENTER Y	A	B	ROTATION ANGLE
2700K	3-Step	0.4578	0.4101	0.0077	0.004	57.2800
	5-Step	0.4578	0.4101	0.0129	0.0067	57.2800
3000K	3-Step	0.4338	0.4030	0.0083	0.0041	53.1600
	5-Step	0.4338	0.4030	0.0139	0.0068	53.1600
3500K	3-Step	0.4073	0.3917	0.0093	0.0041	52.9600
	5-Step	0.4073	0.3917	0.0155	0.0069	52.9600
4000K	3-Step	0.3818	0.3797	0.0094	0.004	54.0000
	5-Step	0.3818	0.3797	0.0156	0.0067	54.0000
5000K	3-Step	0.3447	0.3553	0.0097	0.0036	59.6200
	5-Step	0.3447	0.3553	0.0162	0.006	59.6200
5700K	3-Step	0.3287	0.3417	0.0066	0.0029	58.3800
	5-Step	0.3287	0.3417	0.0110	0.0048	58.3800
6500K	3-Step	0.3123	0.3282	0.0029	0.0066	58.3800
	5-Step	0.3123	0.3282	0.0048	0.011	58.3800

Bin Code	22A1/B/C		27A1/B/C		30A1/B/C		35A1/B/C	
CCT	2200K		2700K		3000K		3500K	
#	x	y	x	y	x	y	x	y
1	0.5115	0.4155	0.4661	0.4122	0.443	0.4063	0.4174	0.3966
2	0.5118	0.4292	0.4644	0.421	0.44	0.4148	0.413	0.4044
3	0.4923	0.4155	0.4497	0.4083	0.4246	0.3998	0.3971	0.3867
4	0.5067	0.4155	0.4628	0.4114	0.4394	0.405	0.4134	0.3946
5	0.507	0.4222	0.462	0.4166	0.4378	0.4101	0.4111	0.3995
6	0.4971	0.4155	0.4529	0.4091	0.4282	0.401	0.4011	0.3886
Bin Code	22A2/D/E		27A2/D/E		30A2/D/E		35A2/D/E	
7	0.5115	0.4155	0.4661	0.4122	0.443	0.4063	0.4174	0.3966
8	0.4927	0.4012	0.4522	0.3989	0.4289	0.3914	0.4035	0.3795
9	0.4923	0.4155	0.4497	0.4083	0.4246	0.3998	0.3971	0.3867
10	0.5067	0.4155	0.4628	0.4114	0.4394	0.405	0.4134	0.3946
11	0.4975	0.4082	0.4546	0.4033	0.431	0.396	0.4054	0.3845
12	0.4971	0.4155	0.4529	0.4091	0.4282	0.401	0.4011	0.3886
Bin Code	40A1/B/C		50A1/B/C		57A1/B/C		65A1/B/C	
CCT	4000K		5000K		5700K		6500K	
#	x	y	x	y	x	y	x	y
1	0.3914	0.3838	0.3541	0.363	0.3357	0.348	0.3192	0.3351
2	0.3856	0.392	0.3458	0.3662	0.3286	0.3489	0.3116	0.335
3	0.3714	0.3731	0.3354	0.3476	0.3217	0.3355	0.3054	0.3214
4	0.3875	0.3816	0.3504	0.36	0.3329	0.3455	0.3165	0.3324
5	0.3842	0.3872	0.3454	0.362	0.3286	0.3461	0.312	0.3324
6	0.3754	0.3752	0.339	0.3506	0.3245	0.3379	0.3081	0.3241
Bin Code	40A2/D/E		50A2/D/E		57A2/D/E		65A2/D/E	
7	0.3914	0.3838	0.3541	0.363	0.3357	0.348	0.3192	0.3351
8	0.3788	0.3679	0.3438	0.3445	0.3287	0.3343	0.3133	0.3218
9	0.3714	0.3731	0.3354	0.3476	0.3217	0.3355	0.3054	0.3214
10	0.3875	0.3816	0.3504	0.36	0.3329	0.3455	0.3165	0.3324
11	0.3802	0.3726	0.3442	0.3487	0.3287	0.3372	0.313	0.3244
12	0.3754	0.3752	0.339	0.3506	0.3245	0.3379	0.3081	0.3241

Notes:

Tester tolerance: ± 0.01 in x and y coordinates

Requirements for application and reflow soldering

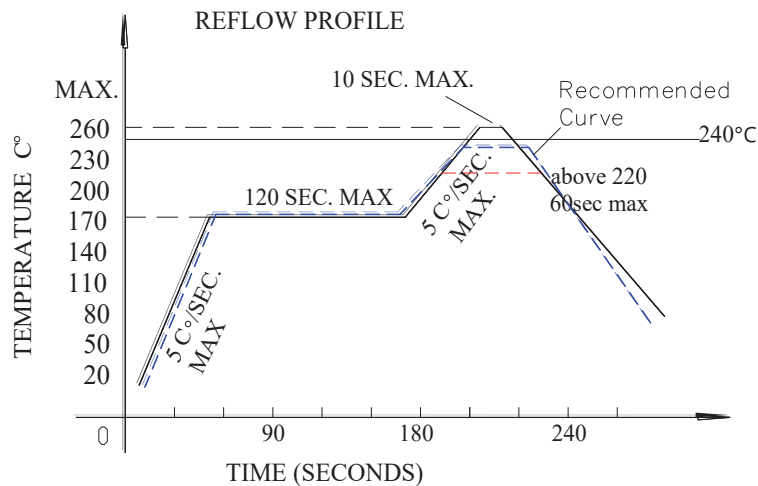

Reflow soldering curve

(Product is highest resistant to 260°C reflow but suggested the highest temperature of 240°C within)

Notes for reflow soldering

- 1.No more than twice for reflow soldering.
- 2.To ensure the quality of our LEDs, we encapsulate them with silica gels. So please do not put pressure on the LEDs.
- 3.Please choose the right nozzle(try to learn from the plastic products parts) to avoid the damage to products due to the pressure.
- 4.Please put on the antistatic hand loop during the use. The worktable should be with antistatic finish. The equipments must be contacted with ground.

Handwork soldering

- 1.During the soldering, the electronic soldering iron must be kept under the temperature of 300°C and the soldering time must not be beyond 3 seconds. No touch between the electronic soldering iron and colloid.
- 2.Handwork soldering is only allowed once. We won't take responsibility for more than that.
- 3.Avoid using sharp objects to compress products Colloidal Part directly.
- 4.Please put on the antistatic hand loop during the use. The worktable should be with antistatic finish. The equipments must be contacted with ground.